

Art.-Nr.: 10.04.01.00187

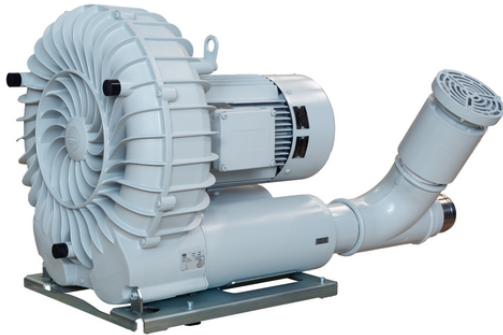

## Technical data

Rated power at 60 Hz	13.20 kW
Voltage at 60 Hz	230 / 460 V - three phase A.C.
Weight	125.000 kg
Suction rate (60 Hz)	1,240.000 m <sup>3</sup> /h
Color	RAL 7035 Light grey
Version	IE3:US/CAN
Vacuum (60 Hz)	260 mbar
Voltage 60 Hz	230/460AC3
Approval	UL/CSA

SB 1240 260 13.2 IE3-TYP2

The vacuum blower SB is delivered as a ready-to-connect product.

Available accessories: silencer box, dust filter

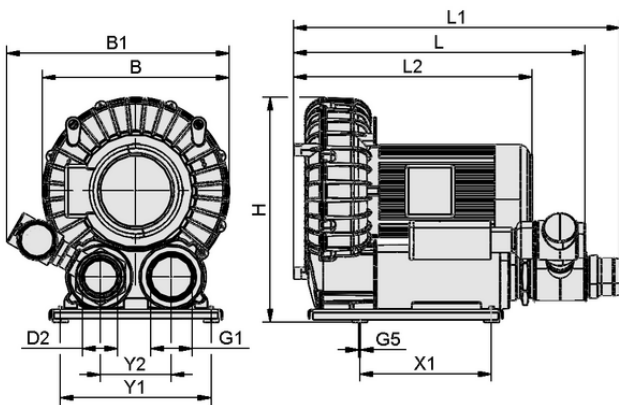

Design data SB 1240 260 13.2 IE3-TYP2

## Design data

Length L1	1,039.00 mm
Length L	663.00 mm
Width B	626.00 mm
Height H	611.00 mm
Outside diameter D2	100.0 mm
Thread G1	G4"-F
Hole spacing Y1	400.0 mm
Hole spacing X1	350.0 mm
Thread G5	M8-F

Art.-Nr.: 10.04.01.00187

**Technical data**

Protection type IP	IP 55
Rated power at 60 Hz	13.20 kW
Voltage at 60 Hz	230 / 460 V - three phase A.C.
Weight	125.000 kg
Suction rate (60 Hz)	1,240.000 m <sup>3</sup> /h
Sound pressure level at 50 Hz	77.0 dB(A)
Version	IE3:US/CAN
Vacuum (60 Hz)	260 mbar
Product family	SB
Version design	IE3-TYP2
Sound pressure level at 60 Hz	79.0 dB(A)
Approval	UL/CSA

Noise level according to DIN EN ISO 3744 (uncertainty factor KpA = 3 dB(A)), interval of 1 m, at medium load, both connection sides piped

**Ordering Data Accessories 10.04.01.00187**

Typ		Item number
Silencer (round)	SD R4-AG 205x538 SGBL	10.04.04.00164
Dust filter	STF 100 P 24.0 SSD	10.07.01.00401
Filter insert (round)	FILT-EINS 3 240x539 PAP STF-Picl-24	10.07.01.00083

