

Art.-Nr.: 10.02.02.04561



SXMPi 30 IMP H PC M12-8

Technical data

Nozzle diameter	3.0 mm
Electrical connection	Male connect M12, 8 pol
Protection type IP	IP 65
Max. vacuum	-850 mbar
Sound pressure level free	72.0 dB(A)
Air consumption suction	380.0 l/min
Suction rate (max.)	220.0 l/min
Communication	IO-Link (Class A)
Pressure range (operating pressure) [bar]	3.0 ... 6.0 bar
Control valve	Impulse valve
Operation mode	Pressure Control
Pneumatic connection	Horizontal

Compact ejector SXPi / SXMPi is delivered as a ready-to-connect product (without connection cable).

Available spare parts: connection cable, base plate, ejector tester

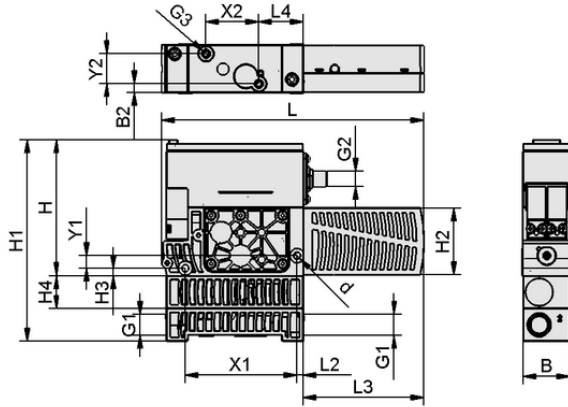

Art.-Nr.: 10.02.02.04561

**Design data**

Length L2	5.00 mm
Length L	210.00 mm
Width B2	6.80 mm
Width B	39.00 mm
Height H1	160.00 mm
Height H2	54.00 mm
Height H	108.00 mm
Internal diameter d	5.50 mm
Thread G1	G3/8"-F
Thread G2	M12x1-M
Length L3	97.00 mm
Length L4	35.50 mm
Height H3	6.00 mm
Height H4	26.00 mm
Hole spacing Y1	10.0 mm
Hole spacing Y2	24.0 mm
Hole spacing X1	89.0 mm
Hole spacing X2	42.0 mm
Thread G3	M5-F

Design data SXMPi 30 IMP H PC M12-8

**Technical data**

Nozzle diameter	3.0 mm
Recommended hose internal diameter compressed air	8.0 mm
Recommended hose internal diameter vacuum	9.0 mm
Degree of evacuation	85.0 %
Sound pressure level free	72.0 dB(A)
Weight	0.910 kg
Max. air consumption blow-off	320.0 l/min
Air consumption suction	13.419 cfm
Suction rate (max.)	7.769 cfm
Pressure range (operating pressure) [bar]	3.0 ... 6.0 bar
Operating temperature	0 ... 50 °C
Pressure range (operating pressure) [psi]	43.5 ... 87.0
Product family	SXMPi
Control valve	Impulse valve

Note: The supply voltage for vacuum switches and solenoid valves is 24V DC Air consumption: At optimal operating pressure Hose diameter: For max. length 2 m

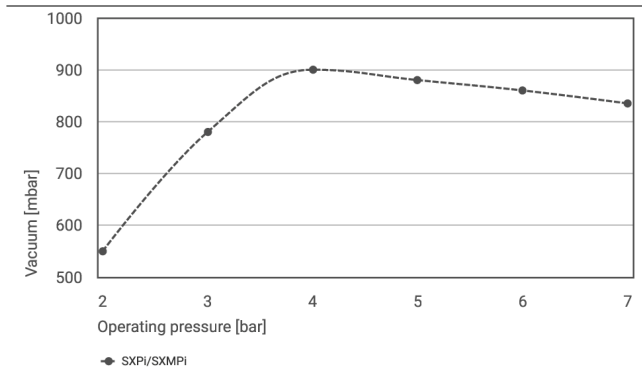

Art.-Nr.: 10.02.02.04561

**Performance data**

Achievable vacuum at various operating pressures

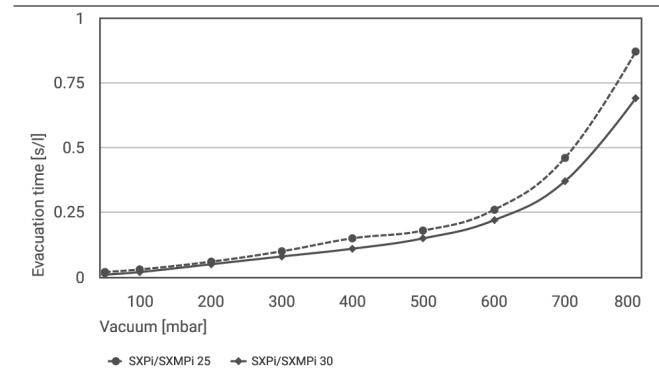

Evacuation time for various vacuum ranges [s/l]

**Achievable vacuum at various operating pressures**

	2	3	4	5	6	7
SXPI/SXMPi	550.00	780.00	900.00	880.00	860.00	835.00

**Evacuation time for various vacuum ranges [s/l]**

	50	100	200	300	400	500	600	700	800
SXPI/SXMPi 25	0.02	0.03	0.06	0.10	0.15	0.18	0.26	0.46	0.87
SXPI/SXMPi 30	0.01	0.02	0.05	0.08	0.11	0.15	0.22	0.37	0.69

**Ordering Data Accessories 10.02.02.04561**

Typ		Item number
Connection cable	ASK B-M12-8 5000 K-8P	21.04.05.00079
Connection cable	ASK B-M12-5 5000 K-5P	21.04.05.00080
Connection cable	ASK B-M12-8 1000 S-M12-4	21.04.05.00167
Basic plate	GPQ1 122x46x43 SXPI/SXMPi	10.02.02.02473
Basic plate	GPQ2 122x87x48 SXPI/SXMPi	10.02.02.02154
Ejector tester	EJEK-TEST SMPi/SCPi	10.02.02.03588

