

Kit de fijación

SET SBP M4-IG



Art.-Nr.: 10.02.01.00769



Datos técnicos

| | |
|----------------------|--------------------|
| Diseño de aplicación | Eyector básico SBP |
| Longitud L | 50,00 mm |
| Anchura B | 14,00 mm |
| Modelo | M4-IG |

SET SBP M4-IG

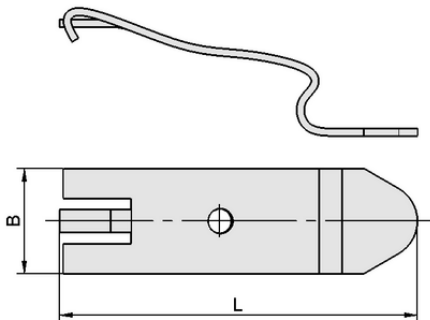

Datos de diseño

| | |
|------------|----------|
| Longitud L | 50,00 mm |
| Anchura B | 14,00 mm |

Datos de diseño SET SBP M4-IG



Datos técnicos

| | |
|------|---------|
| Peso | 16,70 g |
|------|---------|



WWW.SCHMALZ.COM/10.02.01.00769