

Art.-Nr.: 10.01.38.10053

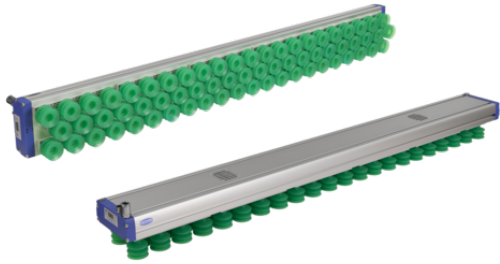

FA-Xi SVK 1234 3R54 SPB2-40P

Technical data

Attribute	Value
Function	Intelligent
Length L	1,234.00 mm
Width B	130.00 mm
Suction cup type	Bellows suction cups SPB2
Diameter Ds	40.0 mm
Valve type	Check valve
Shape	Push In
Suction force at -250 mbar	720.00 N
Arrangement suction cells	3 rows, 54 mm

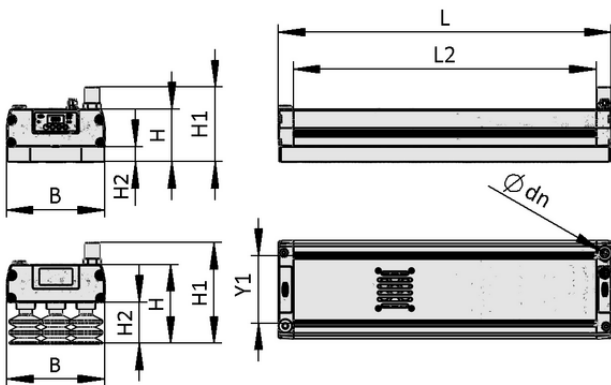

Design data FA-Xi SVK 1234 3R54 SPB2-40P

Design data

Attribute	Value
Length L2	1,194.00 mm
Length L	1,234.00 mm
Width B	130.00 mm
Height H1	134.00 mm
Height H2	55.00 mm
Height H	105.00 mm
Nominal diameter dn	12.00 mm
Suction cup type	Bellows suction cups SPB2
Diameter Ds	40.0 mm
Hole spacing Y1	90.0 mm
Valve type	Check valve

Art.-Nr.: 10.01.38.10053

**Technical data**

Attribute	Value
Construction vacuum switch	PNP switching
Degree of evacuation	67.0 %
Sound pressure level suction	75.0 dB(A)
Weight	7.800 kg
Air consumption [l/min]	905.0 l/min
Number of suction cells	66
Function	Intelligent
Optimal operating pressure	5.00 bar
Suction rate (max.)	2,370.0 l/min
Size	2x100
Control valve	Normally open
Voltage	24V - DC
Electrical connection	Fem connect M12, 5 pol
Sealing element	Suction Cups
Shape	Push In
Suction force at -250 mbar	720.00 N
Arrangement suction cells	3 rows, 54 mm

The air consumption is valid for a workpiece/handling process typical of the application, but may deviate from this both upwards and downwards in a specific use case.

**Further documentation**

CAD data and other documents relating to the article can be found at: www.schmalz.com/10.01.38.10053

**Ordering Data Accessories 10.01.38.10053**

Typ		Item number
Mounting set	SET FA-X/FA-M 4NUTSTEIN	10.01.38.09689
Mounting set	SET FA-X/FA-M	10.01.38.09732
Flange module	MOD-FLAN 120x120 FA-X/FA-M	10.01.38.09734
Flange module	MOD-FLAN 176.6x118 FA-X/FA-M	10.01.38.10701
Suspension, flexible	FST-FLEX 50 HD1 G1/2-AG G3/8-IG	10.01.10.05687
Suspension, rigid	FST-STARR 50 HD1 G1/2-AG G3/8-IG	10.01.10.05809
Flexolink	FLK G1/2-IG G1/2-AG	10.01.03.00175
Flange plate	FLAN-PL 120x85x10 ST FA-X/FA-M	10.01.38.09746
Flange plate	FLAN-PL 120x120x10 FA-X/FA-M	10.01.38.09733
Connection cable	ASK B-M12-5 5000 K-5P	21.04.05.00080
Connection cable	ASK B-M12-5 2000 S-M12-5	21.04.05.00211
Distributor	ASV SM/CPI B-M12-5 2xS-M12-4	10.02.02.03490



Art.-Nr.: 10.01.38.10053



Ordering Data Spare Parts 10.01.38.10053

Typ		Item number
Ball	KUG 5.2 5401 CR-ST G100	10.02.02.02414
Sealing frame	DI-RA 116.6x48.9 EPDM FA-Xc	10.01.38.08523
Silencer (cube-shaped-inst.)	SD 141.9x96x40 FA-X	10.01.38.08509



Ordering Data Wear Parts 10.01.38.10053

Typ		Item number
Bellows suction cup (round)	SPB2 40 SI-55 P	10.01.06.03126

