

Vacuum Area Gripping System FA-X
FA-Xc SVK 442 3R18 O20



Art.-Nr.: 10.01.38.10029



FA-Xc SVK 442 3R18 O20

Technical data

Attribute	Value
Material type	Foam open, height 20 mm
Function	Controlled
Length L	442.00 mm
Width B	130.00 mm
Valve type	Check valve
Suction force at -250 mbar	550.00 N
Arrangement suction cells	3 rows, 18 mm

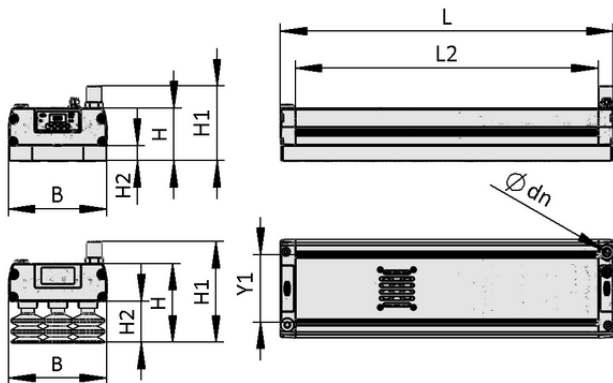

Design data FA-Xc SVK 442 3R18 O20

Design data

Attribute	Value
Length L2	402.00 mm
Length L	442.00 mm
Width B	130.00 mm
Height H1	99.00 mm
Height H2	20.00 mm
Height H	70.00 mm
Nominal diameter dn	12.00 mm
Hole spacing Y1	90.0 mm
Valve type	Check valve



Vacuum Area Gripping System FA-X
FA-Xc SVK 442 3R18 O20



Art.-Nr.: 10.01.38.10029



Technical data

Attribute	Value
Construction vacuum switch	PNP switching
Degree of evacuation	71.0 %
Sound pressure level suction	75.0 dB(A)
Weight	2.400 kg
Air consumption [l/min]	350.0 l/min
Material type	Foam open, height 20 mm
Number of suction cells	65
Function	Controlled
Optimal operating pressure	5.00 bar
Suction rate (max.)	910.0 l/min
Size	1x66
Control valve	Normally open
Voltage	24V - DC
Electrical connection	Fem connect M12, 5 pol
Sealing element	Sealing Foam
Suction force at -250 mbar	550.00 N
Arrangement suction cells	3 rows, 18 mm



Further documentation

CAD data and other documents relating to the article can be found at: www.schmalz.com/10.01.38.10029



Ordering Data Accessories 10.01.38.10029

Typ		Item number
Mounting set	SET FA-X/FA-M 4NUTSTEIN	10.01.38.09689
Mounting set	SET FA-X/FA-M	10.01.38.09732
Flange module	MOD-FLAN 120x120 FA-X/FA-M	10.01.38.09734
Flange module	MOD-FLAN 176.6x118 FA-X/FA-M	10.01.38.10701
Suspension, flexible	FST-FLEX 50 HD1 G1/2-AG G3/8-IG	10.01.10.05687
Suspension, rigid	FST-STARR 50 HD1 G1/2-AG G3/8-IG	10.01.10.05809
Flexolink	FLK G1/2-IG G1/2-AG	10.01.03.00175
Flange plate	FLAN-PL 120x85x10 ST FA-X/FA-M	10.01.38.09746
Flange plate	FLAN-PL 120x120x10 FA-X/FA-M	10.01.38.09733
Connection cable	ASK B-M12-5 5000 K-5P	21.04.05.00080
Connection cable	ASK B-M12-5 2000 S-M12-5	21.04.05.00211



WWW.SCHMALZ.COM/10.01.38.10029

Art.-Nr.: 10.01.38.10029



Ordering Data Spare Parts 10.01.38.10029

Typ		Item number
Ball	KUG 5.2 5401 CR-ST G100	10.02.02.02414
Sealing frame	DI-RA 116.6x48.9 ZEL PU FA-Xc	10.01.38.08523
Vacuum gauge	VAM 40 V U BAR	10.07.02.00046
Silencer (cube-shaped-inst.)	SD 141.9x96x40 FA-X	10.01.38.08509



Ordering Data Wear Parts 10.01.38.10029

Typ		Item number
Seal. plate (FXP-i/FMP-i/FA-X/FA-M)	DI-PL 442x128 3R18 LL-20x7 O20 KE	10.01.38.07232

