

Çan vantuz (yuvarlak)

SAX 60 ED-85 G3/8-AG



Art.-Nr.: 10.01.19.00357



SAX 60 ED-85 G3/8-AG

Çeşitli çaplarda mevcut olan SAX vantuz, elastomer parçaya vulkanize edilmiş bağlantı nipeli ile birlikte teslim edilir.

Teknik veriler

Attribute	Value
Vantuz malzemesi	Elastodur ED
Malzeme sertliği [Shore A]	85,0 Shore A
Boyut	60,00
Körük Sayısı	0,0
Bağlantı	G3/8"-M

SAX 60 ED-85 G3/8-AG

Çeşitli çaplarda mevcut olan SAX vantuz, elastomer parçaya vulkanize edilmiş bağlantı nipeli ile birlikte teslim edilir.

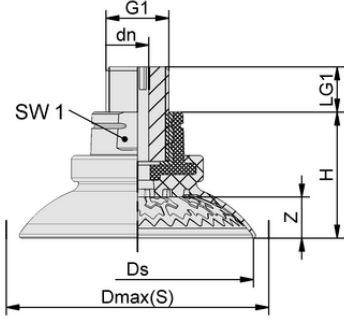

Tasarım verileri

Attribute	Value
Yükseklik H	33,40 mm
Nominal çap dn	6,10 mm
Diş G1	G3/8"-M
Diş uzunluğu LG1	12,0 mm
Anahtar boyutu SW1	22,0 mm
Yay stroku Z	10,9 mm
Çap Ds	61,5 mm
Çap Dmax(S)	69,7 mm

Tasarım verileri SAX 60 ED-85 G3/8-AG



WWW.SCHMALZ.COM/10.01.19.00357

Çan vantuz (yuvarlak)

SAX 60 ED-85 G3/8-AG



Art.-Nr.: 10.01.19.00357



Teknik veriler

Attribute	Value
Vantuz malzemesi	Elastodur ED
Malzeme sertliği [Shore A]	85,0 Shore A
İş parçası yarıçapı dak (dışbükey)	30,0 mm
Emme kuvveti (-600mbar)	154,00 N
Ağırlık	35,00 g
Yanal kuvvet	107,0 N
Yanal kuvvet yağlı yüzey	155,0 N
Cilt	25,200 cm ³
Boyut	60,00
Körük Sayısı	0,0
Bağlantı	G3/8"-M
Ürün ailesi	SAX

Note: Suction force: The suction force values are theoretical values at -0.6 bar vacuum and a dry, smooth and even workpiece surface – they are specified without safety factors. Hose inner diameter: The recommended hose diameter refers to a hose length of approx. 2 m



Further documentation

CAD data and other documents relating to the article can be found at: www.schmalz.com/10.01.19.00357



WWW.SCHMALZ.COM/10.01.19.00357