

Art.-Nr.: 10.01.12.04641



Technical data

Height H	100.00 mm
Arrangement	Can be turned 360°
Version	PRO
Dimension (LxW)	130x30
Dimension suction plate bottom	160x115 mm

VCBL-K2-PRO 130x30x100 D-360

The vacuum block VCBL-K2-PRO is delivered assembled. The product consists of:

- Top suction plate of type VCSP-O - elastomer part, available in various dimensions and suction areas
- Base body made of plastic
- Bottom suction plate type VCSP-U - Elastomer part

Available spare parts: suction plate (top), wear parts set, suction plate (bottom), sealing frame, friction plate, spare parts set with steel inserts, touch valve

Available accessories: Suction plate foam rubber

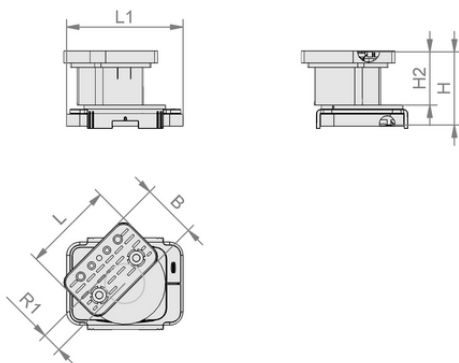

Design data

Length L1	160.00 mm
Length L	130.00 mm
Width B	30.00 mm
Height H2	73.00 mm
Height H	100.00 mm

Design data VCBL-K2-PRO 130x30x100 D-360



Vacuum block

VCBL-K2-PRO 130x30x100 D-360



Art.-Nr.: 10.01.12.04641



Technical data

Dimension suction plate bottom	160x115 mm
--------------------------------	------------



Ordering Data Spare Parts 10.01.12.04641

Typ		Item number
Set of parts subject to wear	VST VCSP 130x30	10.01.12.02348
Suction plate (bottom)	VCSP-U 160x115x16.5 VCBL-K2 TPE	10.01.12.04402
Vacuum block guide strip	VCFL 152x126x26.5 VCBL-K2	10.01.12.04059
Set of parts subject to wear	VST VCBL-K2	10.01.12.02149



WWW.SCHMALZ.COM/10.01.12.04641