

Bellows suction cup (oval)

SAOXB 110x55 ED-85 M12-AG



Art.-Nr.: 10.01.06.06036



Technical data

Suction cup material	Elastodur ED
Material hardness [Shore A]	85.0 Shore A
Number of folds	1.5
Dimension (LxW)	110x55
Nipple material	Aluminum

SAOXB 110x55 ED-85 M12-AG

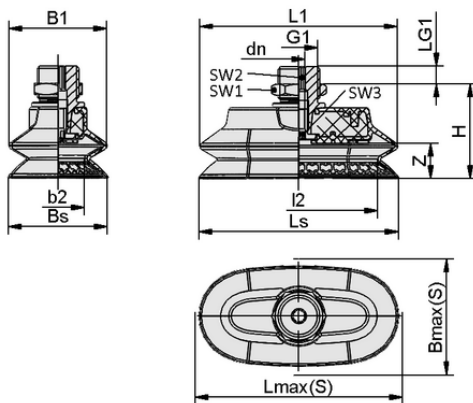

Design data

Length L1	108.50 mm
Width B1	53.30 mm
Height H	42.40 mm
Nominal diameter dn	4.50 mm
Thread G1	M12-M
Thread length LG1	8.5 mm
Key width SW1	18.0 mm
Spanner size SW2	5.0 mm
Spring stroke Z	17.0 mm
Suction cup width Bs	54.00 mm
Ls	110.00 mm
Key width SW3	5.0 mm
Lmax.(S)	114.00 mm
Bmax(S)	60.00 mm
Length L2	89.00 mm
Width B2	33.50 mm

Design data SAOXB 110x55 ED-85 M12-AG



WWW.SCHMALZ.COM/10.01.06.06036

1

Art.-Nr.: 10.01.06.06036

**Technical data**

Suction cup material	Elastodur ED
Material hardness [Shore A]	85.0 Shore A
Workpiece radius min. (convex)	25.0 mm
Pull-off force	190.10 N
Suction force (-600mbar)	155.00 N
Lateral force	91.7 N
Lateral force oily surface	97.6 N
Volume	72.300 cm ³
Number of folds	1.5
Effective suction area	49.73 mm ²
Product family	SAOXB
Dimension (LxW)	110x55
Nipple material	Aluminum

Note: Suction force: The suction force values are theoretical values at -0.6 bar vacuum and a dry, smooth and even workpiece surface – they are specified without safety factors. Hose inner diameter: The recommended hose diameter refers to a hose length of approx. 2 m

**Ordering Data Spare Parts 10.01.06.06036**

Typ		Item number
Bellows suction cup (oval)	SAOXB 110x55 ED-85 SC043	10.01.06.05783

