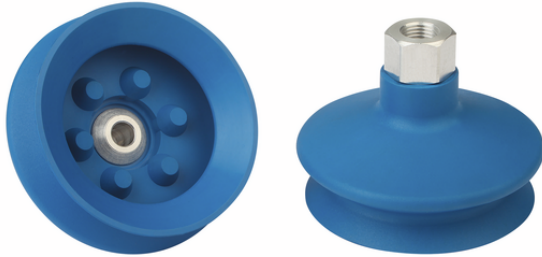

Art.-Nr.: 10.01.06.02479

**Technical data**

Attribute	Value
Suction cup material	High temperature material HT1
Material hardness [Shore A]	60.0 Shore A
Size	78.00
Number of folds	1.5
Connection	G1/4"-F
Vacuum connection	G1/4"-F
Nipple material	Aluminum

FSGA 78 HT1-60 G1/4-IG

Suction cup FSGA (elastomer part + connection nipple) is delivered unassembled (diameters of 33 mm and more are assembled). The delivery consists of:

- Suction cup of type FGA – elastomer part, available in various diameters and materials
- Connection nipple of type SA-NIP – available with various threads

Available spare parts: suction cup FGA, connection nipple SA-NIP

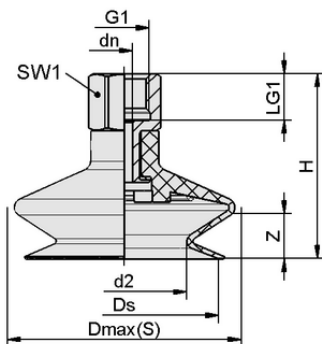
**Design data**

Attribute	Value
Height H	62.00 mm
Nominal diameter dn	8.20 mm
d2	54.0 mm
Thread G1	G1/4"-F
Thread length LG1	12.0 mm
Key width SW1	21.0 mm
Spring stroke Z	16.0 mm
Diameter Ds	74.0 mm
Diameter Dmax(S)	84.5 mm

Note: Acceptable dimensional tolerances for elastomer parts concerning to DIN ISO 3302-1 M3

Design data FSGA 78 HT1-60 G1/4-IG



Art.-Nr.: 10.01.06.02479

**Technical data**

Attribute	Value
Suction cup material	High temperature material HT1
Material hardness [Shore A]	60.0 Shore A
Hose inner diameter (recom.) d	6.0 mm
Workpiece radius min. (convex)	100.0 mm
Pull-off force	218.00 N
Suction force (-600mbar)	137.40 N
Weight	71.00 g
Volume	75.583 cm <sup>3</sup>
Size	78.00
Number of folds	1.5
Product family	FSGA
Connection	G1/4-IG

Note: Suction force: The specified suction forces are theoretical values at a vacuum of -0.6 bar and with a dry, smooth and even workpiece surface - they do not include a safety factor Pull-off force: The pull-off force of the versions made of natural rubber is reduced by about 40% Hose diameter: The recommended hose diameter refers to a hose length of approx. 2 m

**Further documentation**

CAD data and other documents relating to the article can be found at: [www.schmalz.com/10.01.06.02479](http://www.schmalz.com/10.01.06.02479)

**Ordering Data Spare Parts 10.01.06.02479**

Typ		Item number
Suction Cup Connection Nipples	SA-NIP N019 G1/4-IG DN820	10.01.06.01960

**Ordering Data Wear Parts 10.01.06.02479**

Typ		Item number
Bellows suction cup (round)	FGA 78 HT1-60 N019	10.01.06.02474

