

Bellows suction cups (round)  
**FSGA 11 HT1-60 M5-AG**



Art.-Nr.: 10.01.06.01227



FSGA 11 HT1-60 M5-AG

Suction cup FSGA (elastomer part + connection nipple) is delivered unassembled (diameters of 33 mm and more are assembled). The delivery consists of:

- Suction cup of type FGA – elastomer part, available in various diameters and materials
- Connection nipple of type SA-NIP – available with various threads

Available spare parts: suction cup FGA, connection nipple SA-NIP

**Technical data**

Suction cup material	High temperature material HT1
Material hardness [Shore A]	60.0 Shore A
Size	11.00
Number of folds	1.5
Connection	M5-M
Vacuum connection	M5-M
Nipple material	Aluminum

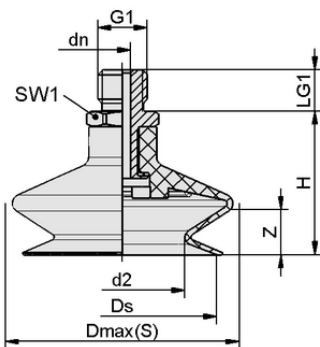

Design data FSGA 11 HT1-60 M5-AG

**Design data**

Height H	21.00 mm
Nominal diameter dn	2.50 mm
d2	5.1 mm
Thread G1	M5-M
Thread length LG1	5.0 mm
Key width SW1	7.0 mm
Spring stroke Z	4.0 mm
Diameter Ds	10.4 mm
Diameter Dmax(S)	13.0 mm

Note: Acceptable dimensional tolerances for elastomer parts concerning to DIN ISO 3302-1 M3

Bellows suction cups (round)  
**FSGA 11 HT1-60 M5-AG**



Art.-Nr.: 10.01.06.01227



**Technical data**

Suction cup material	High temperature material HT1
Material hardness [Shore A]	60.0 Shore A
Hose inner diameter (recom.) d	2.0 mm
Workpiece radius min. (convex)	10.0 mm
Pull-off force	3.80 N
Suction force (-600mbar)	0.95 N
Weight	2.00 g
Volume	0.225 cm <sup>3</sup>
Size	11.00
Number of folds	1.5
Product family	FSGA
Connection	M5-AG

Note: Suction force: The specified suction forces are theoretical values at a vacuum of -0.6 bar and with a dry, smooth and even workpiece surface - they do not include a safety factor Pull-off force: The pull-off force of the versions made of natural rubber is reduced by about 40% Hose diameter: The recommended hose diameter refers to a hose length of approx. 2 m



**Ordering Data Accessories 10.01.06.01227**

Typ		Item number
Schmalz Pad Insert PEEK	SPI 11 PEEK	10.01.06.03281



**Ordering Data Spare Parts 10.01.06.01227**

Typ		Item number
Suction Cup Connection Nipples	SA-NIP N016 M5-AG DN250	10.01.06.00123



**Ordering Data Wear Parts 10.01.06.01227**

Typ		Item number
Bellows suction cup (round)	FGA 11 HT1-60 N016	10.01.06.01247

