

Bellows suction cups (round)
FSGA 16 SI-55 G1/8-IG



Art.-Nr.: 10.01.06.00069



Technical data

Suction cup material	Silicone SI
Material hardness [Shore A]	55.0 Shore A
Size	16.00
Number of folds	1.5
Connection	G1/8"-F
Vacuum connection	G1/8"-F
Nipple material	Aluminum
Material characteristics	FDA-compatible

FSGA 16 SI-55 G1/8-IG

Suction cup FSGA (elastomer part + connection nipple) is delivered unassembled (diameters of 33 mm and more are assembled). The delivery consists of:

- Suction cup of type FGA – elastomer part, available in various diameters and materials
- Connection nipple of type SA-NIP – available with various threads

Available spare parts: suction cup FGA, connection nipple SA-NIP

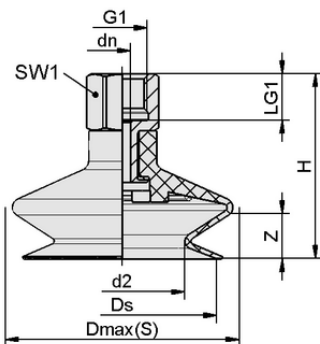

Design data

Height H	31.20 mm
Nominal diameter dn	3.50 mm
d2	8.4 mm
Thread G1	G1/8"-F
Thread length LG1	8.0 mm
Key width SW1	14.0 mm
Spring stroke Z	7.0 mm
Diameter Ds	15.6 mm
Diameter Dmax(S)	18.5 mm

Note: Acceptable dimensional tolerances for elastomer parts concerning to DIN ISO 3302-1 M3

Design data FSGA 16 SI-55 G1/8-IG



WWW.SCHMALZ.COM/10.01.06.00069

Bellows suction cups (round)
FSGA 16 SI-55 G1/8-IG



Art.-Nr.: 10.01.06.00069



Technical data

Suction cup material	Silicone SI
Material hardness [Shore A]	55.0 Shore A
Hose inner diameter (recom.) d	4.0 mm
Workpiece radius min. (convex)	20.0 mm
Pull-off force	6.70 N
Suction force (-600mbar)	3.30 N
Weight	5.40 g
Volume	0.750 cm ³
Size	16.00
Number of folds	1.5
Product family	FSGA
Connection	G1/8-IG

Note: Suction force: The specified suction forces are theoretical values at a vacuum of -0.6 bar and with a dry, smooth and even workpiece surface - they do not include a safety factor Pull-off force: The pull-off force of the versions made of natural rubber is reduced by about 40% Hose diameter: The recommended hose diameter refers to a hose length of approx. 2 m



Ordering Data Accessories 10.01.06.00069

Typ	Item number
Schmalz Pad Insert PEEK SPI 17 PEEK	10.01.06.03283



Ordering Data Spare Parts 10.01.06.00069

Typ	Item number
Suction Cup Connection Nipples SA-NIP N016 G1/8-IG DN350	10.01.06.05731



Ordering Data Wear Parts 10.01.06.00069

Typ	Item number
Bellows suction cup (round) FGA 16 SI-55 N016	10.01.06.00099



WWW.SCHMALZ.COM/10.01.06.00069