

Düz vantuz (oval)

SAOF 60x23 NBR-45 RA



Art.-Nr.: 10.01.05.00563



Teknik veriler

Vantuz malzemesi	Nitril kauçuk NBR
Malzeme sertliđi [Shore A]	45,0 Shore A
Bađlantı	RA
Boyutlar (LxW)	60x23
Meme ucu malzemesi	Alüminyum

SAOF 60x23 NBR-45 RA

Çeşitli çaplarda mevcut olan SAOF vantuz, elastomer parçaya vulkanize edilmiş bađlantı nipelini ile birlikte teslim edilir.

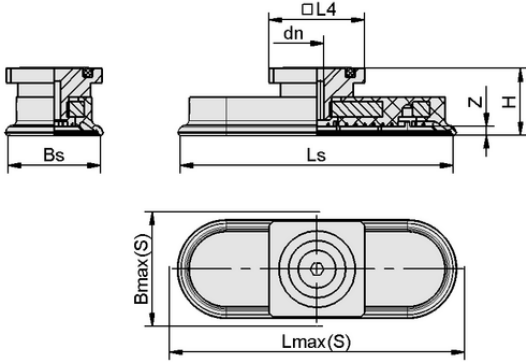

Tasarım verileri

Yükseklik H	21,00 mm
Nominal çap dn	4,00 mm
Yay stroku Z	3,0 mm
Uzunluk L4	32,00 mm
Vantuz genişliđi Bs	21,60 mm
Ls	60,60 mm
Lmaks.(S)	64,00 mm
Bmax(S)	25,00 mm

Not: DIN ISO 3302-1 M3 uyarınca elastomer parçalar için kabul edilebilir boyut toleransları

Tasarım verileri SAOF 60x23 NBR-45 RA



WWW.SCHMALZ.COM/10.01.05.00563

1

Düz vantuz (oval)

SAOF 60x23 NBR-45 RA



Art.-Nr.: 10.01.05.00563



Teknik veriler

Vantuz malzemesi	Nitril kauçuk NBR
Malzeme sertliđi [Shore A]	45,0 Shore A
Hortum çapı (tavsiye edilen) d	4,0 mm
İş parçası yarıçapı dak (dışbükey)	20,0 mm
Emme kuvveti (-600mbar)	57,00 N
Ağırlık	31,00 g
Yanal kuvvet	37,0 N
Yanal kuvvet yağlı yüzey	33,0 N
Cilt	3,890 cm ³
Körük Sayısı	0,0
Ürün ailesi	SAOF
Boyutlar (LxW)	60x23

Note: Suction force: The specified suction forces are theoretical values at a vacuum of -0.6 bar and with a dry, smooth and even workpiece surface - they do not include a safety factor Lateral force: The specified lateral forces are values measured at a vacuum of -0.6 bar with a dry or oily, smooth, flat workpiece surface. Depending on the workpiece surface and its quality, the actual values may deviate from these values Hose diameter: The recommended hose diameter refers to a hose length of approx. 2 m



WWW.SCHMALZ.COM/10.01.05.00563