

Flat suction cup (oval)

SAOF 60x23 NBR-60 RA



Art.-Nr.: 10.01.05.00373



Technical data

Attribute	Value
Suction cup material	Nitrile rubber NBR
Material hardness [Shore A]	60.0 Shore A
Connection	RA
Dimension (LxW)	60x23
Nipple material	Aluminum

SAOF 60x23 NBR-60 RA

Suction cup SAOF, available in various diameters, is delivered with connection nipple vulcanized to elastomer part.

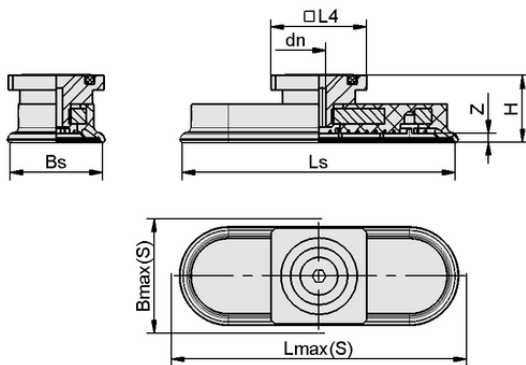

Design data

Attribute	Value
Height H	21.00 mm
Nominal diameter dn	4.00 mm
Spring stroke Z	3.0 mm
Length L4	32.00 mm
Suction cup width Bs	21.60 mm
Ls	60.60 mm
Lmax.(S)	64.00 mm
Bmax(S)	25.00 mm

Note: Acceptable dimensional tolerances for elastomer parts concerning to DIN ISO 3302-1 M3

Design data SAOF 60x23 NBR-60 RA



WWW.SCHMALZ.COM/10.01.05.00373

1

Art.-Nr.: 10.01.05.00373

**Technical data**

Attribute	Value
Suction cup material	Nitrile rubber NBR
Material hardness [Shore A]	60.0 Shore A
Hose inner diameter (recom.) d	4.0 mm
Workpiece radius min. (convex)	20.0 mm
Suction force (-600mbar)	57.00 N
Weight	31.00 g
Lateral force	37.0 N
Lateral force oily surface	33.0 N
Volume	3.890 cm ³
Number of folds	0.0
Product family	SAOF
Dimension (LxW)	60x23

Note: Suction force: The specified suction forces are theoretical values at a vacuum of -0.6 bar and with a dry, smooth and even workpiece surface - they do not include a safety factor Lateral force: The specified lateral forces are values measured at a vacuum of -0.6 bar with a dry or oily, smooth, flat workpiece surface. Depending on the workpiece surface and its quality, the actual values may deviate from these values Hose diameter: The recommended hose diameter refers to a hose length of approx. 2 m

**Further documentation**

CAD data and other documents relating to the article can be found at: www.schmalz.com/10.01.05.00373

