

Flat suction cup (oval)

SAOF 100x50 NBR-60 G3/8-IG



Art.-Nr.: 10.01.05.00272



Technical data

Suction cup material	Nitrile rubber NBR
Material hardness [Shore A]	60.0 Shore A
Connection	G3/8-IG
Dimension (LxW)	100x50
Nipple material	Nickel plated

SAOF 100x50 NBR-60 G3/8-IG

Suction cup SAOF, available in various diameters, is delivered with connection nipple vulcanized to elastomer part.

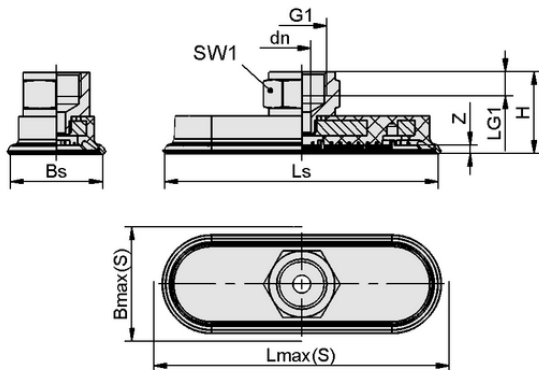

Design data

Height H	30.50 mm
Nominal diameter dn	8.00 mm
Thread G1	G3/8"-F
Thread length LG1	9.0 mm
Key width SW1	22.0 mm
Spring stroke Z	5.0 mm
Suction cup width Bs	48.10 mm
Ls	101.10 mm
Lmax.(S)	106.00 mm
Bmax(S)	54.00 mm

Note: Acceptable dimensional tolerances for elastomer parts concerning to DIN ISO 3302-1 M3

Design data SAOF 100x50 NBR-60 G3/8-IG



WWW.SCHMALZ.COM/10.01.05.00272

Flat suction cup (oval)

SAOF 100x50 NBR-60 G3/8-IG



Art.-Nr.: 10.01.05.00272



Technical data

Suction cup material	Nitrile rubber NBR
Material hardness [Shore A]	60.0 Shore A
Hose inner diameter (recom.) d	6.0 mm
Workpiece radius min. (convex)	75.0 mm
Suction force (-600mbar)	217.00 N
Weight	85.30 g
Lateral force	181.0 N
Lateral force oily surface	121.0 N
Volume	21.800 cm ³
Number of folds	0.0
Product family	SAOF
Dimension (LxW)	100x50

Note: Suction force: The specified suction forces are theoretical values at a vacuum of -0.6 bar and with a dry, smooth and even workpiece surface - they do not include a safety factor Lateral force: The specified lateral forces are values measured at a vacuum of -0.6 bar with a dry or oily, smooth, flat workpiece surface. Depending on the workpiece surface and its quality, the actual values may deviate from these values Hose diameter: The recommended hose diameter refers to a hose length of approx. 2 m



WWW.SCHMALZ.COM/10.01.05.00272